

# WIRE ROPE HOIST CATALOG

PROFESSIONAL  
PROMPT SERVICES



PROFESSIONAL  
PROMPT SERVICES

## **FITOP MACHINERY CO., LTD.**

NO. 12, 34th Road, Industrial Area,  
Taichung, Taiwan, R.O.C.  
Tel: 886-4-2350-6666  
Fax: 886-4-2350-3397 / 2350-2351  
Web: <http://www.fitop.com.tw>  
E-mail: [sales@fitop.com.tw](mailto:sales@fitop.com.tw)

FITOP-20141022

正五傑機械股份有限公司  
FITOP MACHINERY CO., LTD.

## AV TYPE: Single-Girder Hoist

1. Fit to light industrial application with features of swiftness and convenience.
2. The direct electromagnetic brake is accurate, powerful and easily adjusted.
3. The all-planetary reduce gears are made of high frequency treated medium carbon steel.
4. Adopting JIS nominal No. 6 wire rope, provides good durability and flexibility.



## AW TYPE: Double-Rail Hoist

1. Fit to medium tonnage loading (2~15 tons).
2. With direct type electromagnetic brake.
3. The mounted eccentric shaft will function automatically adjusting the traversing movement at balance even the rails are fixed un-evenly.
4. With mere malfunction concern and easy maintenance. Wire rope and long diameter steel hook provide with high efficiency.

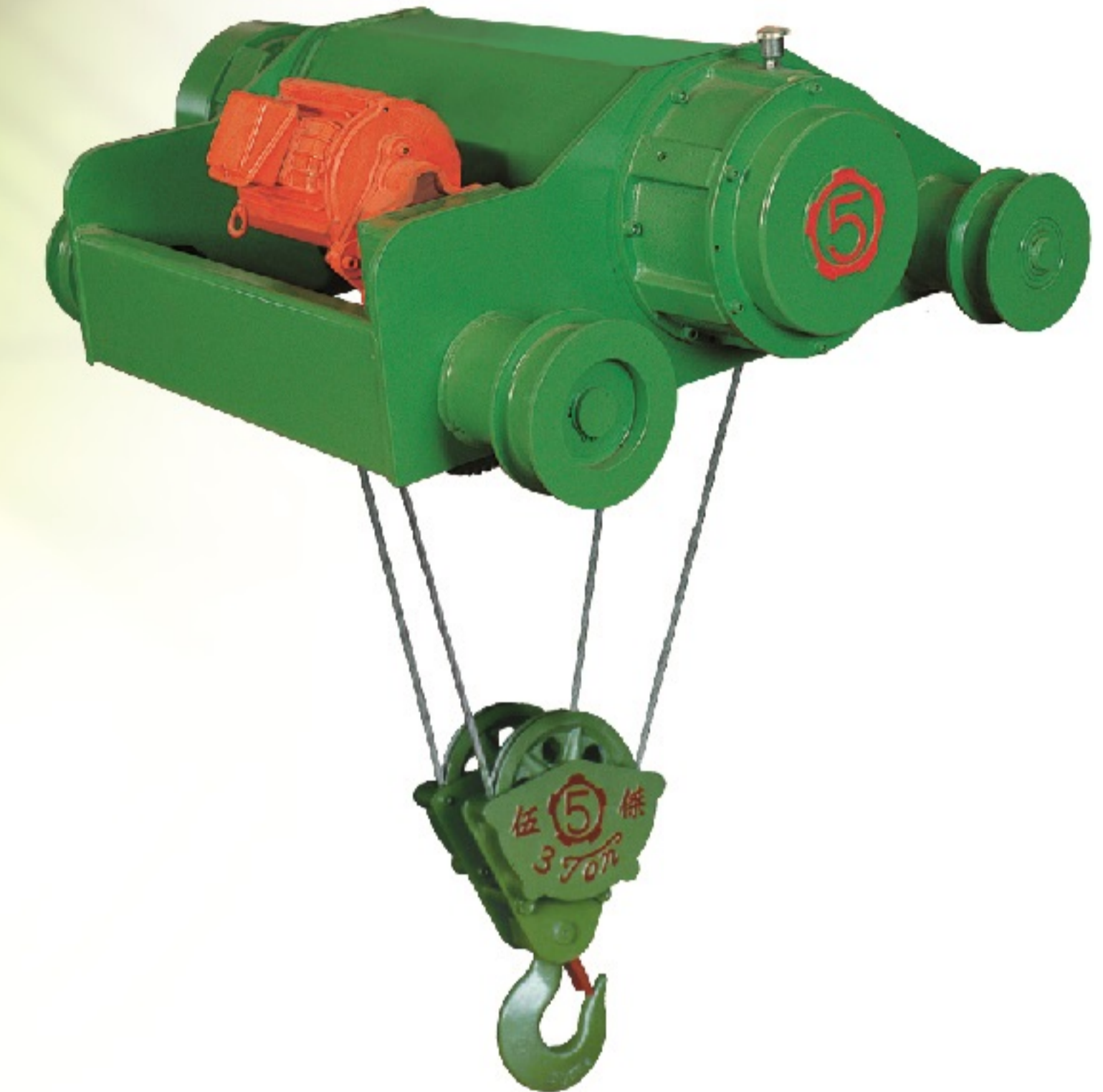

## BW TYPE: Open Crab Type Hoist

1. Applicable for heavy duty tonnage operations.
2. The powerful hydraulic drum type braking system, featuring to assure high effectiveness, steady stopping motion.
3. The mounted eccentric shaft will function automatically adjusting the traversing movement at balance even the rails are fixed un-evenly.

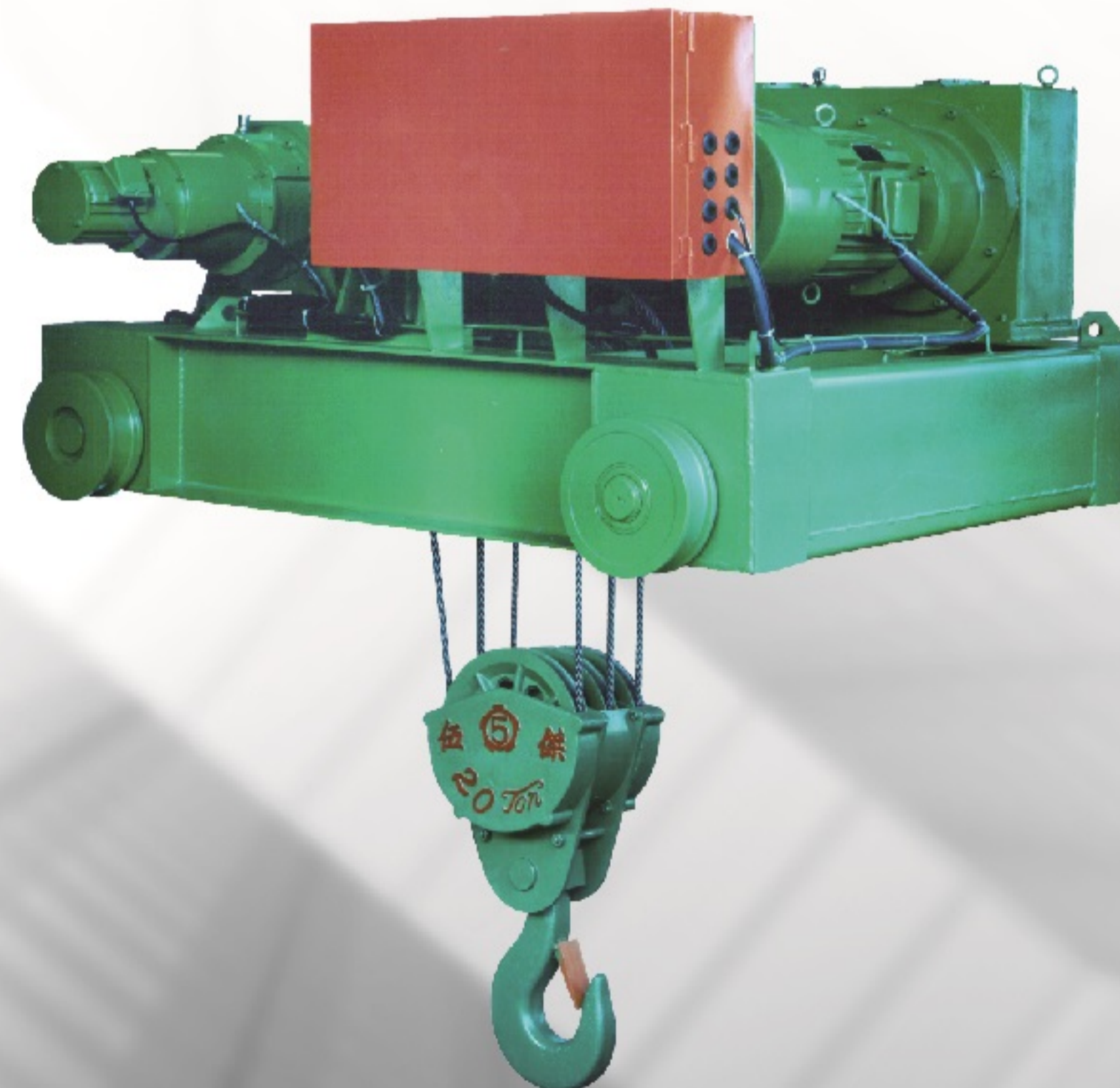

## Twin Crane

1. Two weighting loads hoist.
2. The main hoist is for heavier load while the other is for lighter, to save power consumption.
3. With dual function, only one set of beams and saddle seat required.
4. Provide more operating space without interfering each other, capable for wider loading weights.

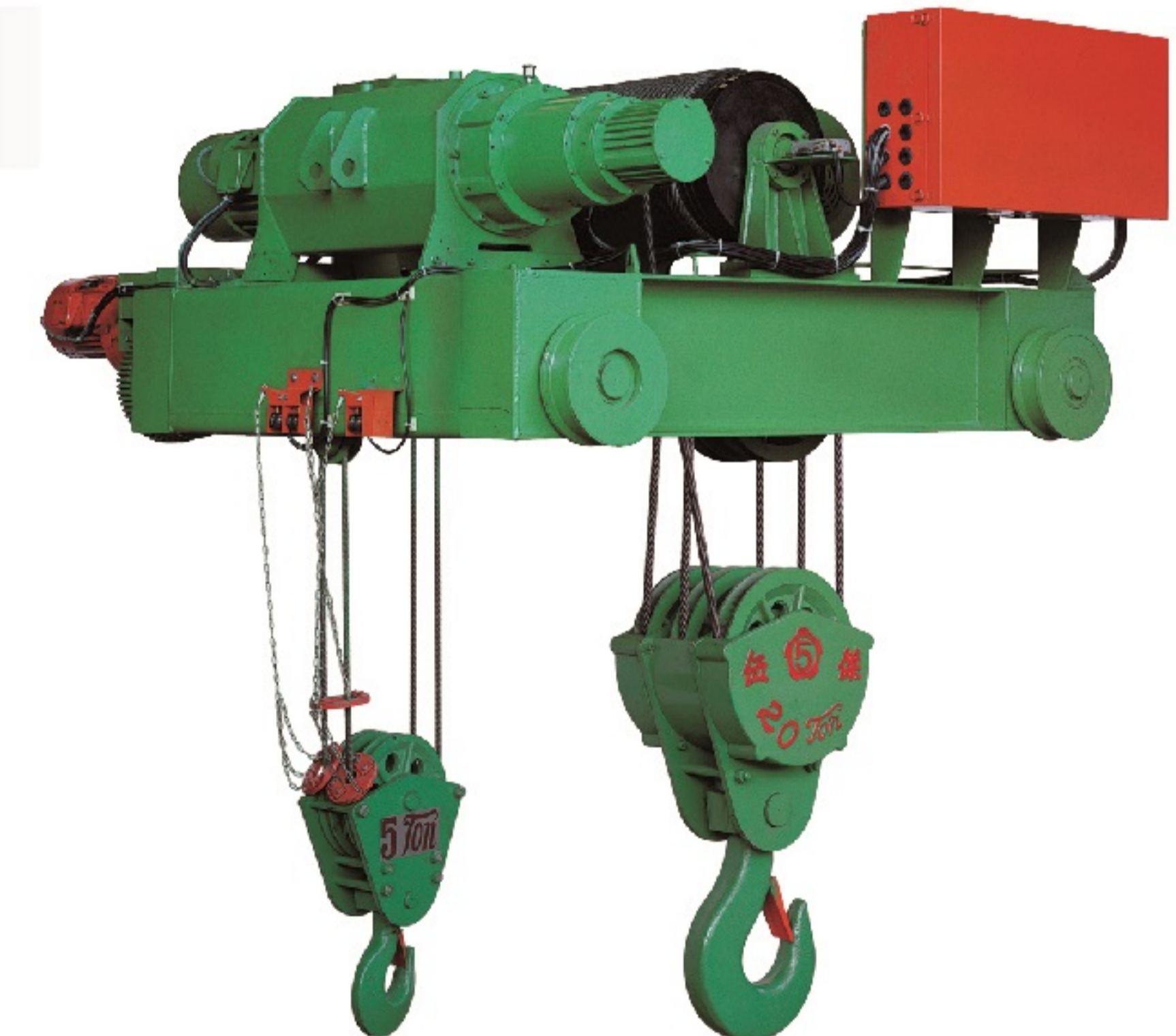

## AT TYPE: Suspension Hoist

1. An ideal model for the environment where the mounting and working space is merely affordable in between the beam to ceiling.
2. Featuring to medium tonnage operations.
3. The mounted eccentric shaft will function automatically adjusting the traversing movement at balance even the rails are fixed un-evenly.

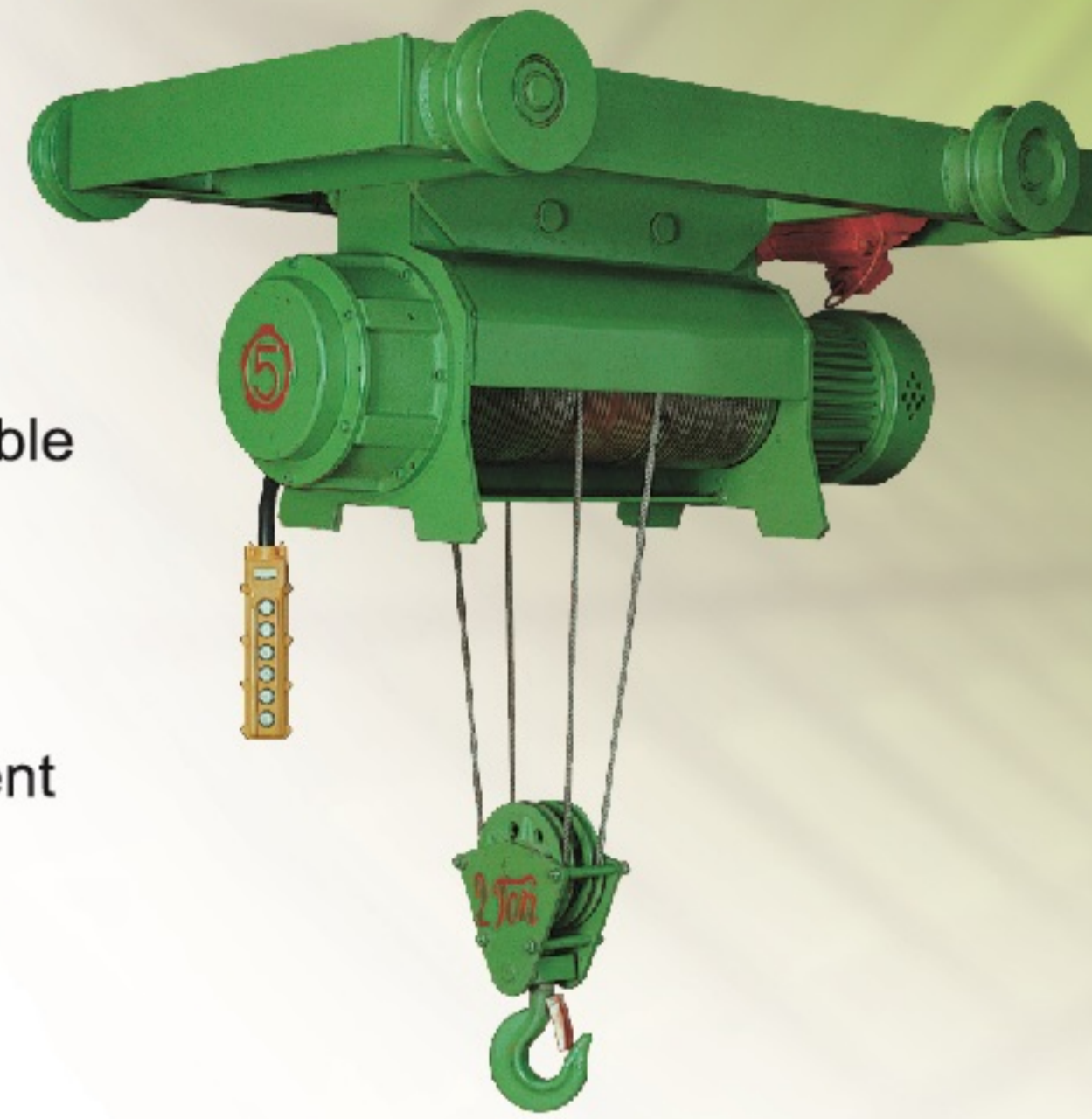

## AU Type: Lower Fixed Type Hoist

1. Applicable to be fixed for vertical hoisting purpose with high safety, cargo elevator ... etc. for instance.
2. Eco-friendly, easy installation and mere malfunction concern.
3. High accurate direct electromagnetic brake, powerful and easily adjusted.
4. The all-planetary reduce gears are made of high frequency treated medium carbon steel.



## AR TYPE: Double-Girder Hoist

1. Suitable for 2~15 tons medium tonnage operations.
2. Its flexible gauge size is readily adaptable to be request.
3. The mounted eccentric shaft will function automatically adjusting the traversing movement at balance even the rails are fixed un-evenly.



## Micro-speed Hoist

1. A created model to fit for fast and slow(inching) lifting speeds in alternative which are request, in precision working ... for instance.
2. All-planetary geared with 1/10 micro speed ratio design. Standardized as per CNS norm, new model No. 36855. Smooth operation in shifting speed mode without jerking and shaking.



## AS TYPE: Upper Fixed Type Hoist

1. Applicable to be fixed for vertical hoisting purpose with high safety, cargo elevator ... etc. for instance.
2. Eco-friendly, easy installation and mere malfunction concern.
3. High accurate direct electromagnetic brake, powerful and easily adjusted.
4. The all-planetary reduce gears are made of high frequency treated medium carbon steel.
5. Drum's OD is 16 times more than cable diameter.
6. The hook is fine steel cast and machined.

## Saddle Seat / End Carriage

1. We offer various types of saddle seats to meet every requirement.
2. Easy assemble and mounting. Adopting ball bearing for smooth movement.
3. A suggestible of self-adjusting with 4 wheels saddle seat which is awarded by Germany, patent No.G88057410, for un-even rails traveling is under request.
4. Tailor made is available.

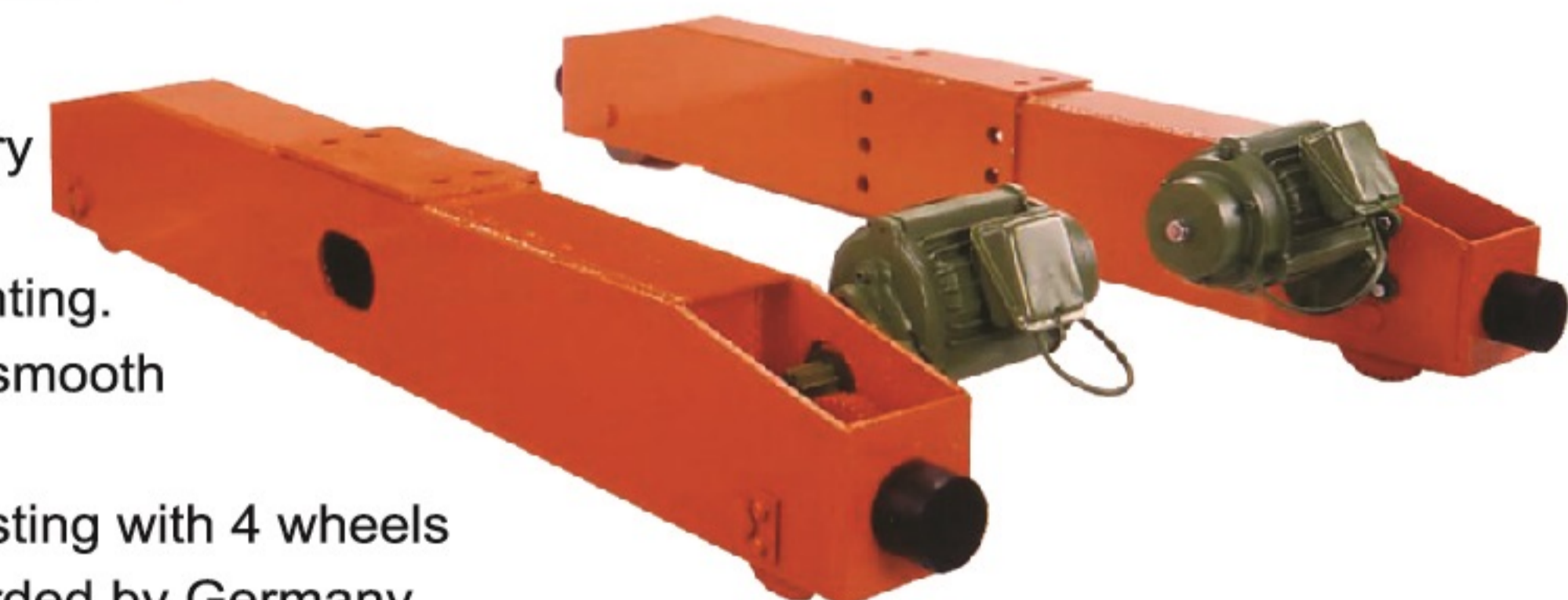

## 1. Hoisting Motor

- Adopts specialized Squirrel-Cage Induction Motor, housed in grey cast iron outer shell. Insulation class: E (for 6HP under), class B (for 6HP above). Class H (optional).
- Optimized and electrical 250% start-up torque force, high durability in long time, frequent operation without noise.
- The classification of the motor made, please refer to page no.18.
- The complied Ingress Protection Ratings is IP53 (IP55 is optional). Standardized single speed motor: 4P; Double speed motor: 4/8P; Micro speed motor: an additional motor is installed beside the gear box.

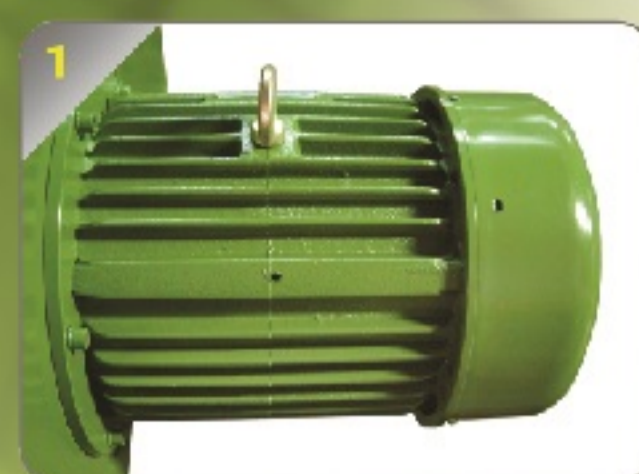

## 2. Gear Box - Planetary

- Compact all-planetary reducer gears, large torque output, low noise.
- Hermetic lubrication type, no oil leaking, long service life. High alloy steel made with heat treated. Gears hardness is all HRC45 grade above. Shaft is made by high friction resistant material.
- Noise level  $\leq 85\text{dba}@1\text{M}$ .



## 3. Wheel

- Machining from S45C material, surface heat-treated. High pressure resistance, excellent wear and tear property.

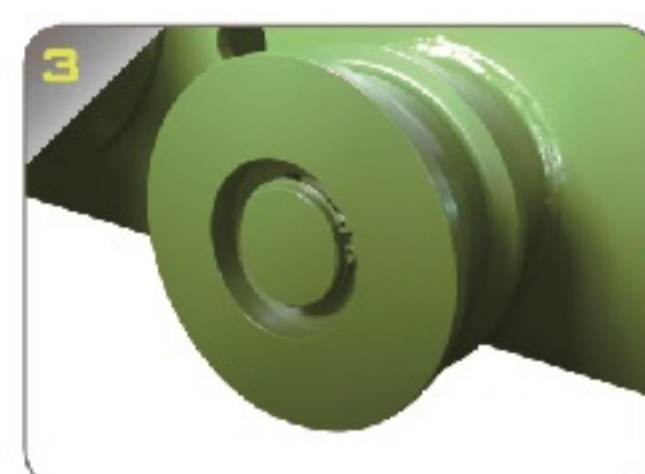

## 4. Wire Rope

- Adopts rope with at least 5 times safety factor. High tensional strength, wear-resistance flexible steel, high durability in bending fatigue.



## 5. Up / Upper Limited Switches

- With second back-up limit switch while the first is failed in winding up. First is to break the circuit and the second is to emergently cut off the main power for securing safety.

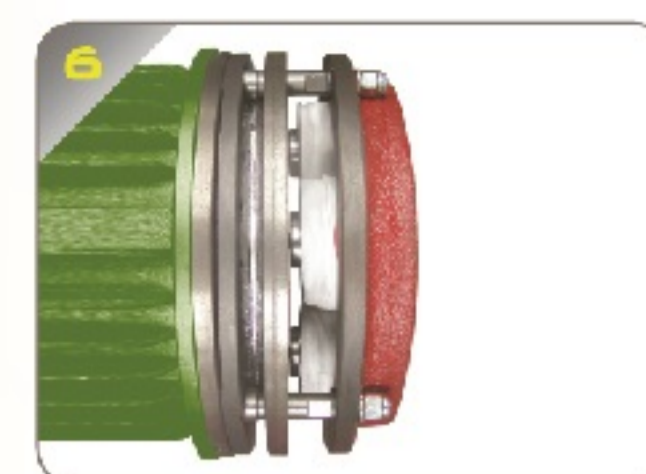

## 6. Brake System

- The designed DC electromagnetic brake disc features to activate at instance and deliver 150% braking force.
- While off power, brake affected mechanically and synchronously. High security, easy adjustment.



## 7. Eccentric Shaft (Patent no. 40602)

- Auto-Adjusting device, to make the trolley or end carriage maintained at balance when traveling on an un-even rail.
- Applicable for medium tonnage operations (2~30 tons). Low malfunction. Easy maintenance.



## 8. Control System

- Adopts renowned brand of electromagnetic switch. Excellent in high duty cycle, inching operation and sustainability in rapid voltage decline.
- Electromagnetic switch is lined up with mechanical linkage. Coil secured by surge protector.
- Control voltage standard is 48V (option: 220; 110V).
- Inverter is available.

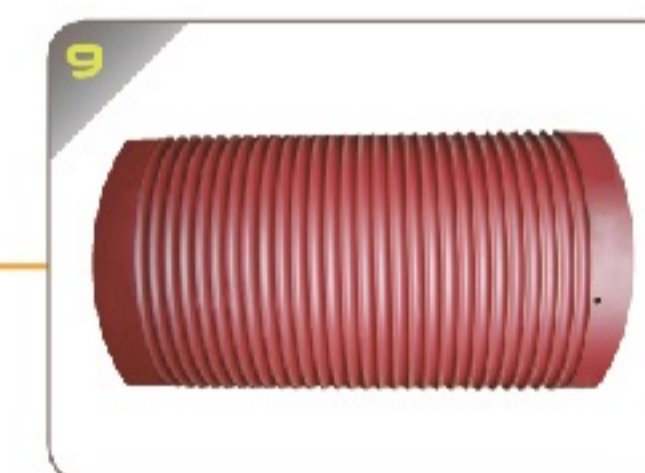

## 9. Drum

- Complying with Fixed Crane safety norm which the diameter is 16 times bigger against wire rope.



## 10. Sheave

- Made of gray iron casting. With diameter which is 18 times bigger against wire rope.



## 11. Push-Button Switch (Pedant)

- An integral shaped reinforced plastic shell. Good insulation and capable to impact and fire resistance.
- Cable attached with high tensional steel wire for securing tensile strength while dropping.



## 12. Hook Assembly

- Forged and heat-treated alloy steel with high tensile and capability in against wear and tear. With thrust bearing enables hook to swivel 360 degrees.
- 4 times safety factor by means of safety latch for securing operation in safe.

## 1. Rope Guide

- To guide the rope onto drum groove correctly while winding up without overlapping. So as to ensure the life span in service of rope.
- Design for easy assemble/disassemble.



## 2. Hollow shaft Gearbox

- Low noise, high efficiency, not only to meet the requirement in special reducing purpose also to be able to offer at tailor made basis.
- Direct assemble without any exposed extruder spinning externally. Secure safety of operator. Easier in maintenance and assemble/disassemble.



## 3. Torque Arm Assembly

- Adopts one point arm fixing which avoids gearbox from being rotated along with spinning force. The fixed disc type spring is to act as damper for shielding abrupt impact and then prolong service life.
- To act, at the mean time, as an ideal buffer upon brake to achieving a double measures in preventing fallen of load.

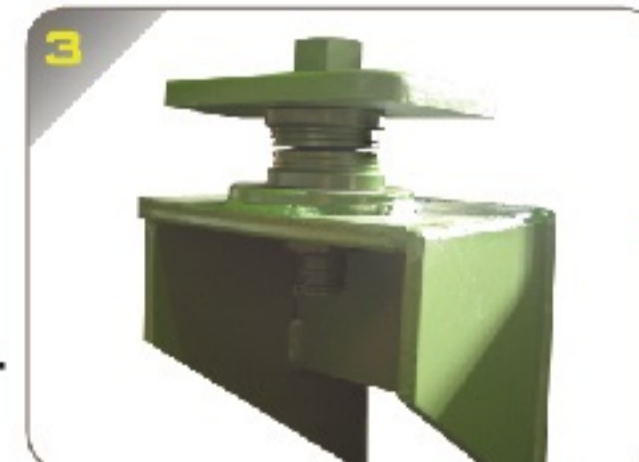

## 4. Pulley and Hook

- Double hook, a special design for large-tonnage loads. Rigid and durable. Made by alloy steel with heat treatment, is able to rotate 360 degrees. 4 times safety grade against load rating. With slippery securing pin for freeing from accident.
- The pulley is made by gray casting iron and 18 times bigger than steel wire rope in diameter.



## 5. Electrical Panel

- Adopts renowned brand of electromagnetic switch. Excellent in high duty cycle, inching operation and sustainability in rapid voltage decline.
- Electromagnetic switch is lined up with mechanical linkage. Coil secured by surge protector.
- Control voltage standard is 48V (option: 220; 110V).
- Inverter is available.

## 6. Motor

- Inverter motor, an ideal and specific to heavy industry, with function of buffering and speed gearing. Gray cast iron for shell structure material. Insulation grade: class F (class H is optional).
- Optimized and electrical 250% start-up torque force, high durability in long time, frequent operation without noise.
- The classification of the motor made, please refer to page no.18.



## 7. Brake System

- The hydraulic and electromagnetic drum brake system is designed for big tonnage hoisting. Accurate braking mechanism with 150% optimized braking force. While off power, brake affected mechanically and synchronously. High security, easy adjustment.
- An additional fan installed to cool down the temperature.



## 8. Overload Protection

- While over loading, power will be off automatically for safety and securing hoist's service life.
- Two options
  - Mechanical type (connect with shaft)
  - E-type mode (on the steel wire rope)

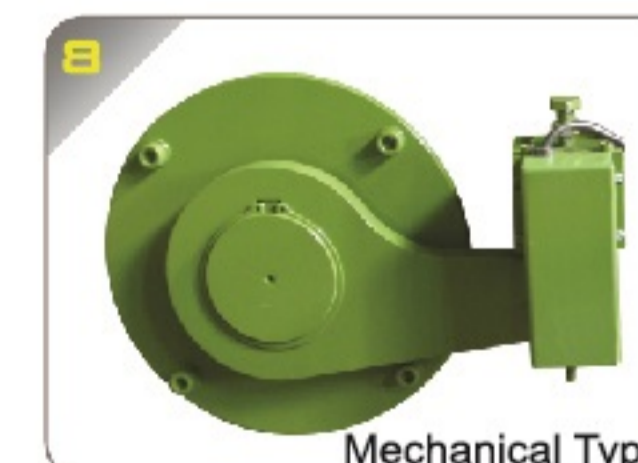

## HONORS AND ACHIEVEMENTS



1988 Bali, Taipei 200 tons crane project



2001 Taiwan High Speed Rail 100 tons gantry crane



2004 VSL Hong Kong 150 tons gantry crane, lift height= 50M



2006 Kao Ming jib crane



2010 Airport Metro Line 260 Tons Gantry Crane Project



1996 Fitop 360 degrees rotary crane



2001 Taiwan High Speed Rail mobile plant



2005 Taipei MRT 10 tons crane

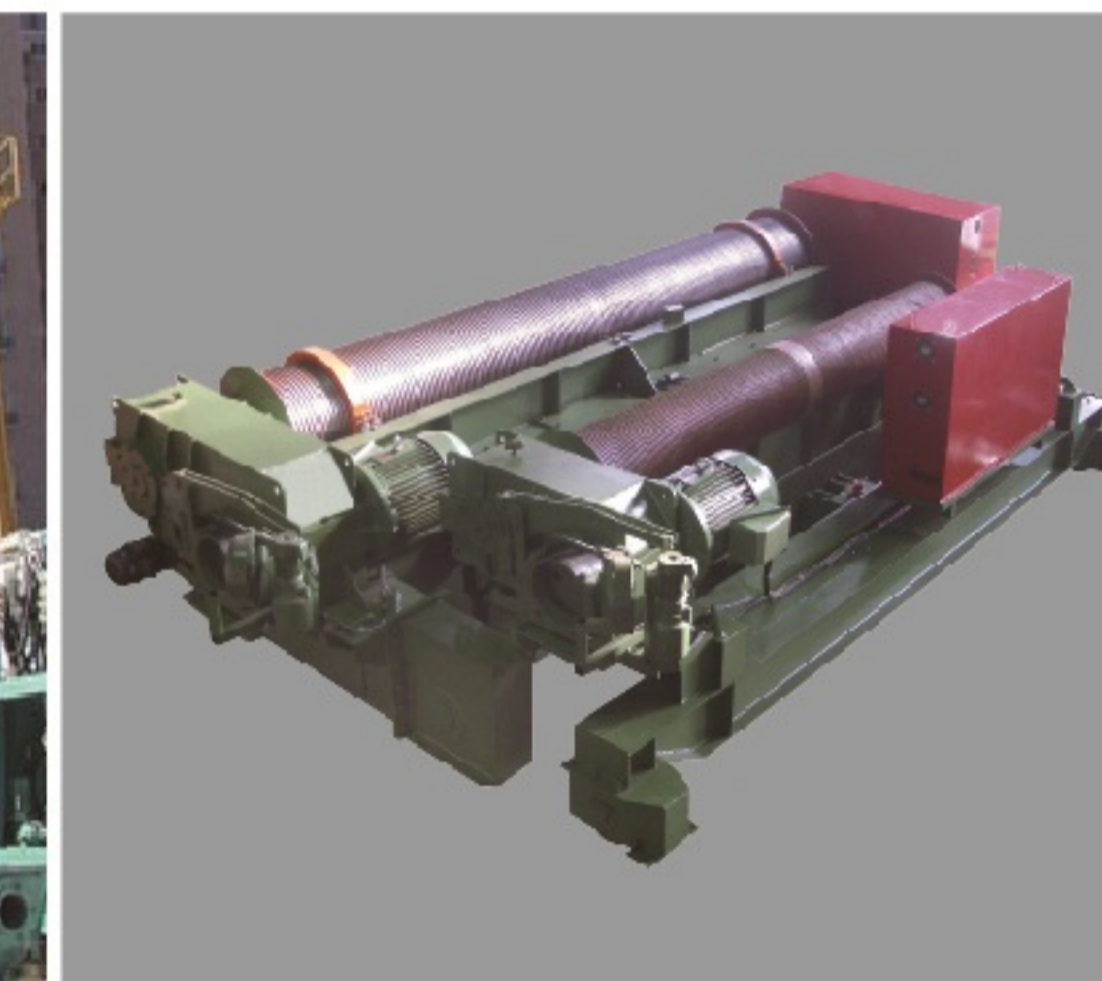

2008 Megastar Hydroelectric power plant 150/35 tons twin hoist



2011 Hong Kong Cruise Terminal 150 Tons Gantry Crane Project



2000 Highway (Kuaiguan sections) Asia's largest bridge



2003 Chin Fong Machinery 100 tons crane lift 16M



2006 Paterson Machinery 3 tons jib crane with 9M height

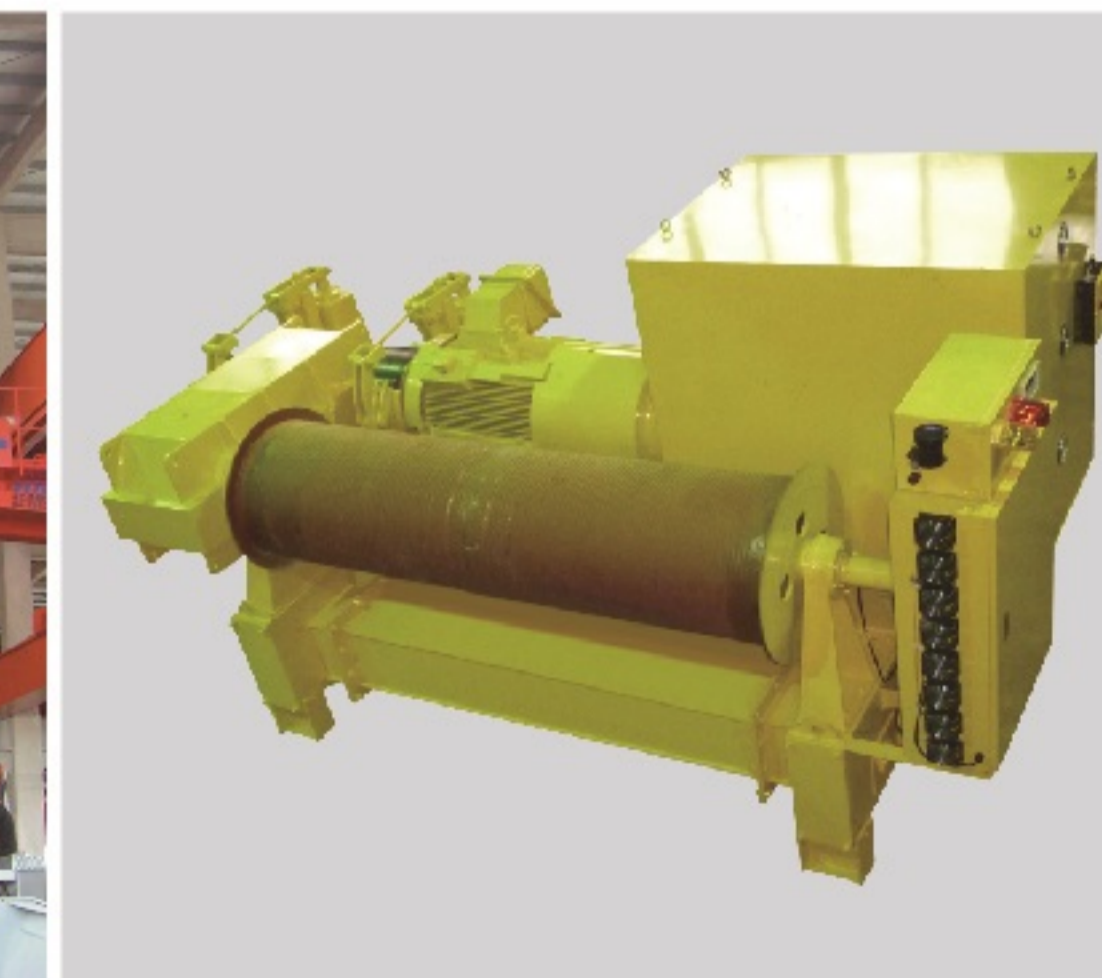

2009 Hong Kong Tsuen Wan Tunnel 105 tons hoist



2011 Hwang Chang General Contractor Co., LTD. C911 Project 80 Tons Crane

# DIMENSION

## AV TYPE

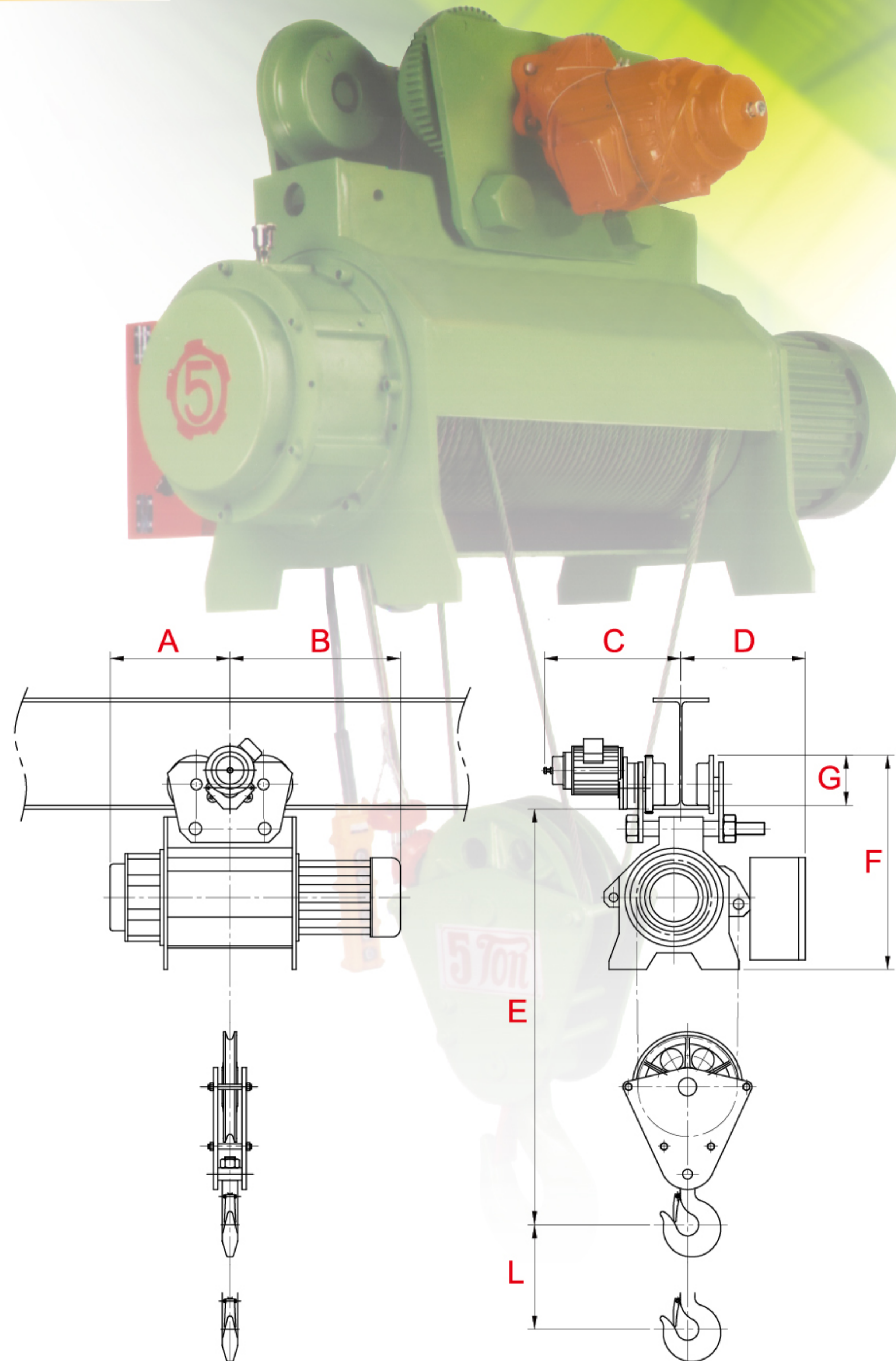

Loading (Tons)	Type Specification	Lifting Height (M)	Hoisting			Trolley				Wire Rope		Dimension (m/m)								Safety Distance	Weight (kg)	
			Lifting Speed		Lifting Motor (kw)	Trolley Speed				Trolley Motor (kw)	Diameter (mm)	Reeving	(m/m)									
			60Hz	50Hz		I Beam	H beam	I Beam	H beam				A	B	C	D	E	F	G			L
1	AV011	5.26	7.2	6	1.5	19.1	17.6	15.9	14.7	0.37	8	1/2	290	395	435	350	790	545	127	5.26	500	200
		380											485	440	340	850	565	140	11.1			
2	AV021	5.55	3.6	3	1.5	17.4	15.8	14.5	13.2	0.37	8	1/4	380	485	440	340	850	565	140	5.55	600	247
		8.79											480	585						8.79		
		12.03											580	685						12.03		
		12.03											580	685						12.03		
	AV022	5.09	7.2	6	3	17.4	15.8	14.5	13.2	0.37	8	2/4	400	580	440	385	845	660	140	5.09	600	371
		8.91											505	685						8.91		
		12.00											590	770						12.00		
		12.00											590	770						12.00		
AV023	10.03	7.2	6	3	17.4	15.8	14.5	13.2	0.37	10	1/2	400	580	440	385	845	660	140	10.03	600	333	
	16.71											505	685						16.71			
	22.12											590	770						22.12			
	22.12											590	770						22.12			
3	AV031	5.01	3.6	3	3	14	12.8	11.7	10.7	0.50	10	1/4	400	580	485	385	1040	670	163	5.01	700	399
		8.36											505	685						8.36		
		11.06											590	770						11.06		
	AV032	4.20	7.2	6	4.5	14	12.8	11.7	10.7	0.50	10	2/4	400	580	485	385	990	670	163	4.2	700	390
		7.54											505	685						7.54		
		10.24											590	770						10.24		
		10.24											590	770						10.24		
		10.24											590	770						10.24		
AV033	7.62	7.2	6	4.5	14	12.8	11.7	10.7	0.50	12	1/2	400	580	485	385	990	670	163	7.62	700	390	
	12.93											505	685						12.93			
	17.23											590	770						17.23			
5	AV051	5.23	3.2	2.7	4.5	14.5	13.4	12.1	11.2	0.50	12	1/4	420	600	485	430	1205	760	187.5	5.23	800	532
		8.70											530	710						8.70		
		12.25											645	825						12.25		
	AV052	4.24	6.4	5.3	7.5	14.5	13.4	12.1	11.2	0.50	12	2/4	425	615	485	430	1135	760	187.5	4.24	800	532
		7.71											535	725						7.71		
	AV053	8.89	6.4	5.3	7.5	14.5	13.4	12.1	11.2	0.50	14	1/2	433	615	485	430	1500	773	185	8.89	800	532
		15.06											545	728						15.06		
		21.37											660	843						21.37		
7.5	AV071	6.09	3.2	2.7	5.6	14.6	13.4	12.2	11.2	0.50	14	1/4	485	675	505	450	1365	885	204	6.09	900	675
		9.11											595	785						9.11		
		12.34											715	905						12.34		
	AV072	5.03	4.8	4	9	14.6	13.4	12.2	11.2	0.50	14	2/4	505	675	505	450	1280	545	127	5.03	500	620
		8.06											615	785						8.06		
		11.29											735	905						11.29		
10	AV101	6.54	2.9	2.4	7.5	14.9	13.6	12.4	11.3	0.50	16	1/4	505	675	515	475	1645	565	140	6.54	600	782
		9.82											615	785						9.82		
		13.33											735	905						13.33		
	AV102	5.02	4.8	4	11.25	14.9	13.6	12.4	11.3	0.50	16	2/4	520	790	515	475	1545	660	140	5.02	600	828
		8.30											630	900						8.30		
		11.81											750	1020						11.81		

# DIMENSION

## AW TYPE

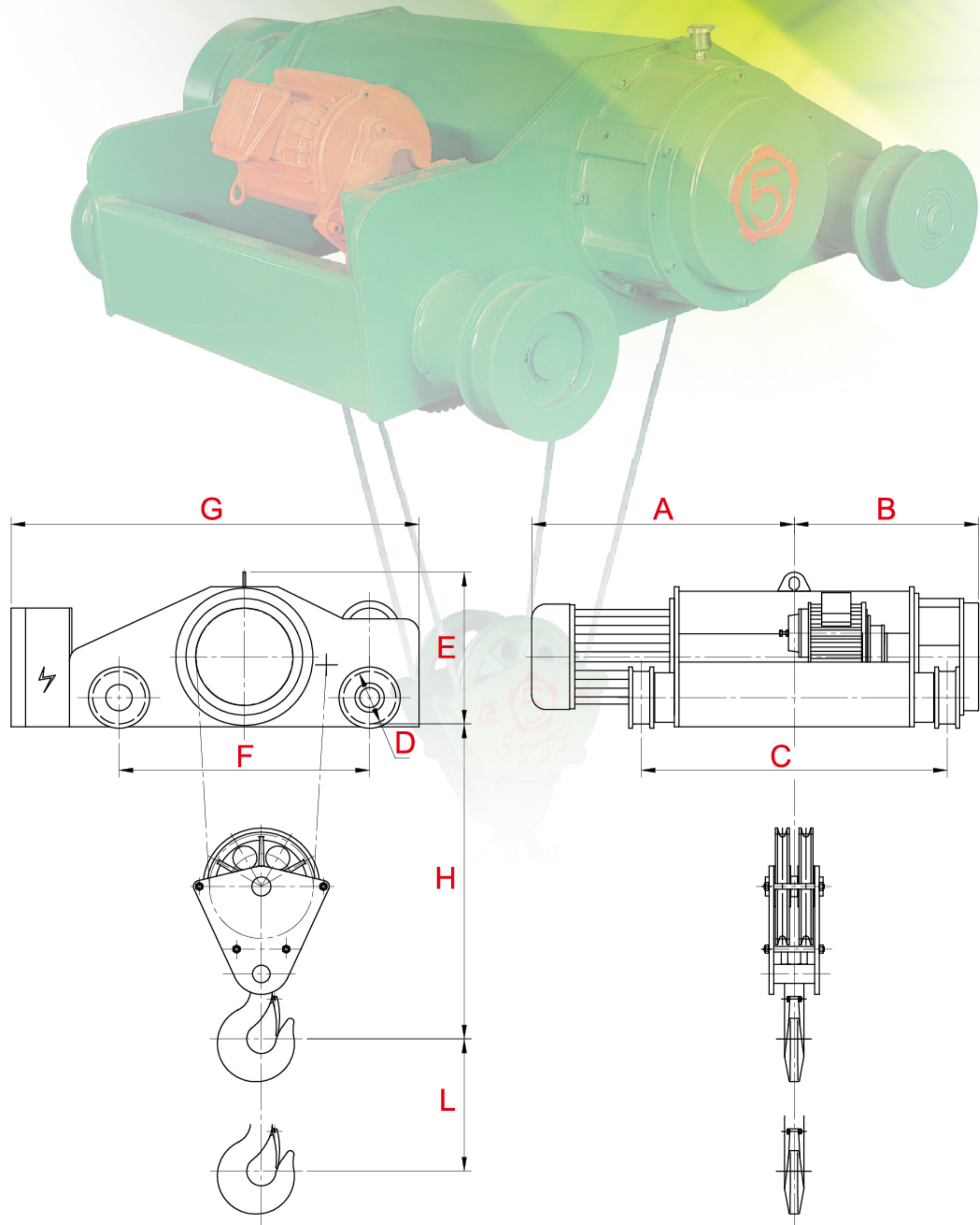

Loading (Tons)	Type Specification	Lifting Height (M)	Hoisting			Trolley			Wire Rope		Dimension (m/m)										Safety Distance	Weight (kg)															
			Lifting Speed	Lifting Motor (kw)	Trolley Speed	Trolley Motor (kw)	Diameter (mm)	Reeving	A	B	C	D	E	F	G	H	L																				
																		60Hz	50Hz	60Hz			50Hz														
1	AW011	11.10	7.2	6	1.5	17.4	14.5	0.37	8	1/2	490	385	680	150	390	580	940	510	11.10	500	264																
2	AW021	5.55	3.6	3	1.5	17.4	14.5	0.37	8	1/4	490	385	680	150	390	650	940	565	5.55	600	273																
		8.79									590	485	880						8.79																		
		12.03									690	585	1080						12.03																		
	AW022	5.09	7.2	6	3	17.4	14.5	0.37	8	2/4	585	405	710	150	420	650	1040	565	5.09	600	387																
		8.91									690	510	920						8.91																		
		12.00									775	595	1090						12.00																		
		AW023									10.03	7.2	6						3			17.4	14.5	0.37	10	1/2	585	405	710	150	420	650	1040	565	10.03	600	380
											16.71																690	510	920						16.71		
											22.12																775	595	1090						22.12		
3	AW031	5.01	3.6	3	3	13.4	11.2	0.50	10	1/4	585	405	710	150	420	650	1040	650	5.01	700	414																
		8.36									690	510	920						8.36																		
		11.06									775	595	1090						11.06																		
	AW032	4.20	7.2	6	4.5	13.4	11.2	0.50	10	2/4	585	405	710	150	420	650	1040	650	4.20	700	395																
		7.54									690	510	920						7.54																		
		10.24									775	595	1090						10.24																		
		AW033									7.62	7.2	6						4.5			13.4	11.2	0.50	12	1/2	585	405	710	150	420	650	1040	650	7.62	700	400
											12.93																690	510	920						12.93		
											17.23																775	595	1090						17.23		
5	AW051	5.24	3.2	2.7	4.5	13.4	11.2	0.50	12	1/4	605	430	750	150	470	700	1110	750	5.24	800	505																
		8.70									725	535	970						8.70																		
		12.25									840	650	1200						12.25																		
	AW052	4.24	6.4	5.3	7.5	13.4	11.2	0.50	12	2/4	620	430	750	150	470	700	1110	750	4.24	800	496																
		7.71									730	540	970						7.71																		
		11.25									845	655	1200						11.25																		
		AW053									8.89	6.4	5.3						7.5			13.4	11.2	0.50	14	1/2	620	430	750	150	470	700	1110	750	8.89	800	525
											15.06																730	540	970						15.06		
											21.37																845	655	1200						21.37		
7.5	AW071	6.09	3.2	2.7	5.6	13.3	11.1	0.50	14	1/4	680	490	830	170	520	750	1180	810	6.09	900	675																
		9.11									790	600	1050						9.11																		
		12.34									910	720	1300						12.34																		
	AW072	5.03	4.8	4	9	13.3	11.1	0.50	14	2/4	795	510	830	170	520	750	1180	810	5.03	900	699																
		8.06									905	620	1050						8.06																		
		11.29									1025	740	1300						11.29																		



# SELECTION OF LIFTING MOTORS

## 1-1 Intermittent Duty: (ED)

1-1-1 The ratio of span in operation and stand-by period which is taken place alternatively under a regular working environment, the result is so-called ED value. It can be found by the equation as under:

$$ED\% = \frac{\text{Operating time}}{(\text{Operating time} + \text{rest time})} \times 100$$

\* The time factor taken in the equation above is based at 10 minutes the maximum. The minimum values of duty cycle allowed are given as table 1.

1-1-2 Number of starts per hour, please refer to table 1

1-1-3 The number of cycles for safe working load, for both lifting and dropping, is calculated as follow:

$$S = 0.3 \times \frac{ED \times V}{H}$$

S= Number of cycles/h. Cycle in accordance with figure 1.

ED= Percentageduty cycle.

V= Lifting speed in M/Min.

H= Average lifting height in M.

The equation stated above is applied by the following assumption:

$$H \leq \frac{ED \times V}{20}$$

The lifting height (H) does not exceed the permitted values which the ED values resulted are under the 10 minutes per cycle.

Permitted operations (starts): Supposed that the average starts per cycle is not exceeded 6 times.

As figure 1, a regular operational cycle comprises Lifting-Stand-by-Dropping-Stand-by 4 stages.

## 1-2 Short Time Duty: (S.D.)

In some extraordinary operation mode (such as longer hooking path), the time of operation must not be exceeded than which is permitted onto the motor adopting itself (for the concerns of allowable heating range). All applicable minimal operational ratings shown in the figure=1.

When the motor's temperature is descending to the acceptable the operation can be carried on in complying with corresponding safety level of which the adopted motor is concerned provided that the starts would not more than 10 times.

## 1-3 Mix-up Duty Modes

The alternative operational mode in between "Intermittence" and "Short Time Duty", the motor's temperature do not exceed to what it is permitted.

Table 1

Class		Intermittent load			Short load
FEM	ISO	Cycle/hour	start times/h	ED%	S.D. minutes during the operation
1Dm	M1	15	90	15	7.5
1Cm	M2	20	120	20	7.5
1Bm	M3	25	150	25	15
1Am	M4	30	180	30	15
2m	M5	40	240	40	30
3m	M6	50	300	50	30
4m	M7	60	360	60	60
5m	M8	60	360	60	>60

The table applies to the lifting motor with one speed only. Under the circumstance of same start numbers (which is in use) the half of the ED value can be obtained by the lifting element. As to the motor is two speeds model, the table 2 as under is applied:

The following ratios will be taken into account:

Table 2

	High speed	Low speed
Start frequency	1/3	2/3
Operational Span	2/3	1/3

Figure 1

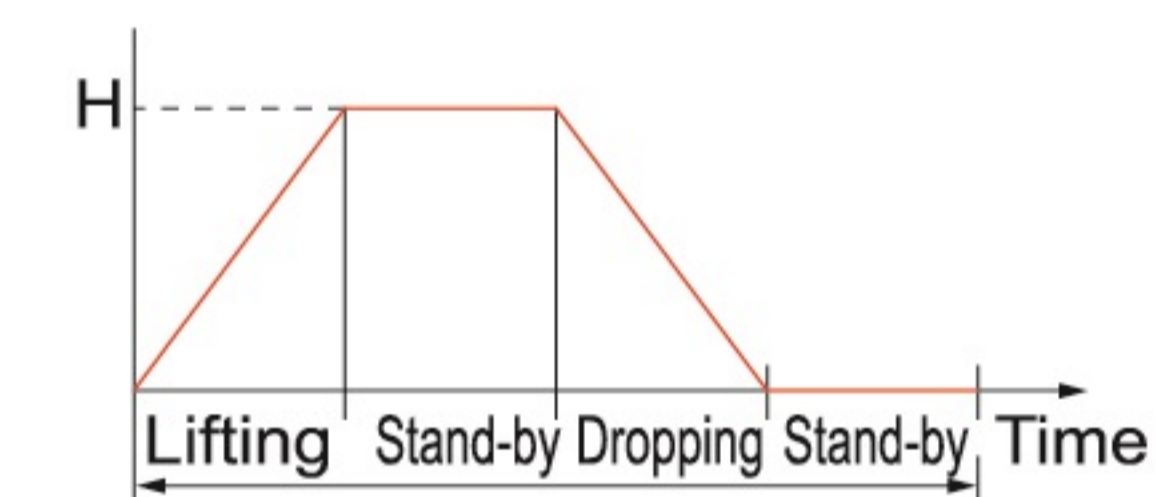

## 1-4 Coding principles

Double Rail Type		Fixed Type, Suspension Type		Single Girder Type		Double Rial Type (AR, AT)	
A	Series	A	Series	A	Series	A	Series
W	Type	U	Type	V	Type	R	Type
051	Models	051	Models	051	Models	05	Models
06	Drum spec.	06	Drum spec.	06	Drum spec.	06	Drum spec.
1	Lifting Ratio	1	Lifting Ratio	1	Lifting Ratio	B	Trolley speed
B	Trolley speed	A	Power	B	Trolley speed	1	Transversing ratio
1	Transversing ratio			1	Transversing ratio	1	Rail
1	Rail			H	Steel Type	A	Power
A	Power			1	Beam width		
				A	Power		