

# LOW HEAD type

Available from 0.49Ton to 5Ton capacity



## LOW HEAD type

- Hoist classification : FEM(1Bm) / ISO(M3)
- Motor & brake class : "F" class
- Ambient temperature : -10°C ~ +40°C
- Intermittent Rating(%ED) :  
single speed(25%ED) dual speed(20%ED)
- Minimized distance between hooks  
: Lower 100mm, 300mm, 700mm than standard type  
: When the building with low ceiling  
: When extended lifting height is required
- Emergency stop
- Powerful motor
- KD manufactured load chain

### I STANDARD SPECIFICATION

Model	Capacity (ton)	Lift (m)	Duty rating (min)		Lifting Speed (m/min)				Traversing Speed (m/min)		Load Chain Dia. (mm)	No. of Falls of Load Chain	Test Load (kg)
			Single	Dual	Single		Dual		50Hz	60Hz			
					50Hz	60Hz	50Hz	60Hz					
KDL-1M	0.49 / 0.5	4	30	15/5	6.7	8	6.7/1.7	8.0/2.0	10 (20)	12 (24)	φ7.1	1	613 / 625
	1	4	30	15/5	6.7	8	6.7/1.7	8.0/2.0	10 (20)	12 (24)	φ7.1	1	1,250
	1.9 / 2	4	30	15/5	3.4	4	3.4/0.9	4.0/1.0	10 (20)	12 (24)	φ7.1	2	2,375 / 2,500
KDL-2M	1.9 / 2	4	30	15/5	6.8	8.2	6.8/2.1	8.2/2.5	10	12	φ11.2	1	2,375 / 2,500
	2.5	4	30	15/5	5.9	7.1	5.9/1.8	7.1/2.2	10	12	φ11.2	1	3,125
	2.8 / 3	4	30	15/5	4.3	5.2	4.3/1.3	5.2/1.6	10	12	φ9.5	2	3,500 / 3,750
KDSL-2M	5	4	30	15/5	3.0	3.6	3.0/0.9	3.6/1.1	10	12	φ11.2	2	6,250

Capacity (kg)	Output (kw)		Traversing (kw)	Net weight (kg)			Extra weight per 1m lift (kg)		
	Single	Dual		KDL-1M	KDL-2M	KDSL-2M	KDL-1M	KDL-2M	KDSL-2M
0.49 / 0.5	0.8	0.8/0.27	0.4	132 (135)	-	-	1.1	-	-
1	1.5	1.5/0.5	0.4	132 (135)	-	-	1.1	-	-
1.9 / 2	1.5	1.5/0.5	0.4	150 (153)	-	-	2.1	-	-
1.9 / 2	3.3	3.3/1.1	0.4	-	205 (215)	-	-	2.7	-
2.5	3.3	3.3/1.1	0.4	-	235 (245)	-	-	2.7	-
2.8 / 3	3.3	3.3/1.1	0.4	-	275 (265)	-	-	4	-
5	3.3	3.3/1.1	0.4	-	290 (300)	360 (370)	-	5.3	5.3

### I DIMENSION

Model	Capacity (ton)	Dimension (mm)										Std.I-Beam Width (mm)	Min. Radius of Curve (mm)
		A	B	C	D	E	H	S	W	P	G		
KDL-1M	0.49 / 0.5	258	268 (315)	75	348	213	121	230	560	663	330	75, 100, 125	-
	1	258	308 (335)	100	360	225	121	230	560	663	330	75, 100, 125	-
	1.9 / 2	258	308 (335)	125	418	245	121	296	626	800	550	100, 125, 150	-
KDL-2M	1.9 / 2	332	360 (390)	125	357	245	123	296	663	900	530	100, 125, 150	-
	2.5	332	360 (390)	125	366	254	136	337	710	950	596	100, 125, 150	-
	2.8 / 3	332	360 (390)	125	366	254	136	337	710	950	650	100, 125, 150	-
KDSL-2M	5	332	360 (390)	125	383	271	158	384	790	1,000	760	125, 150, 175	-

( ) Dual speed Dimension, Specification

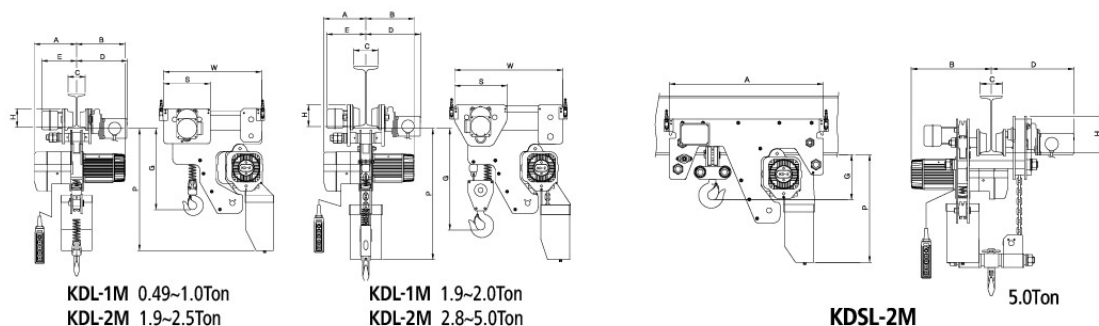

• The design, material and specification are subject to change for improvement without notice.  
 • A special specification is available upon request.  
 • 극동호이스트(주) 제품의 규격은 품질개선을 위하여 예고없이 변경될 수 있으므로 제품 구입시 문의바랍니다.